

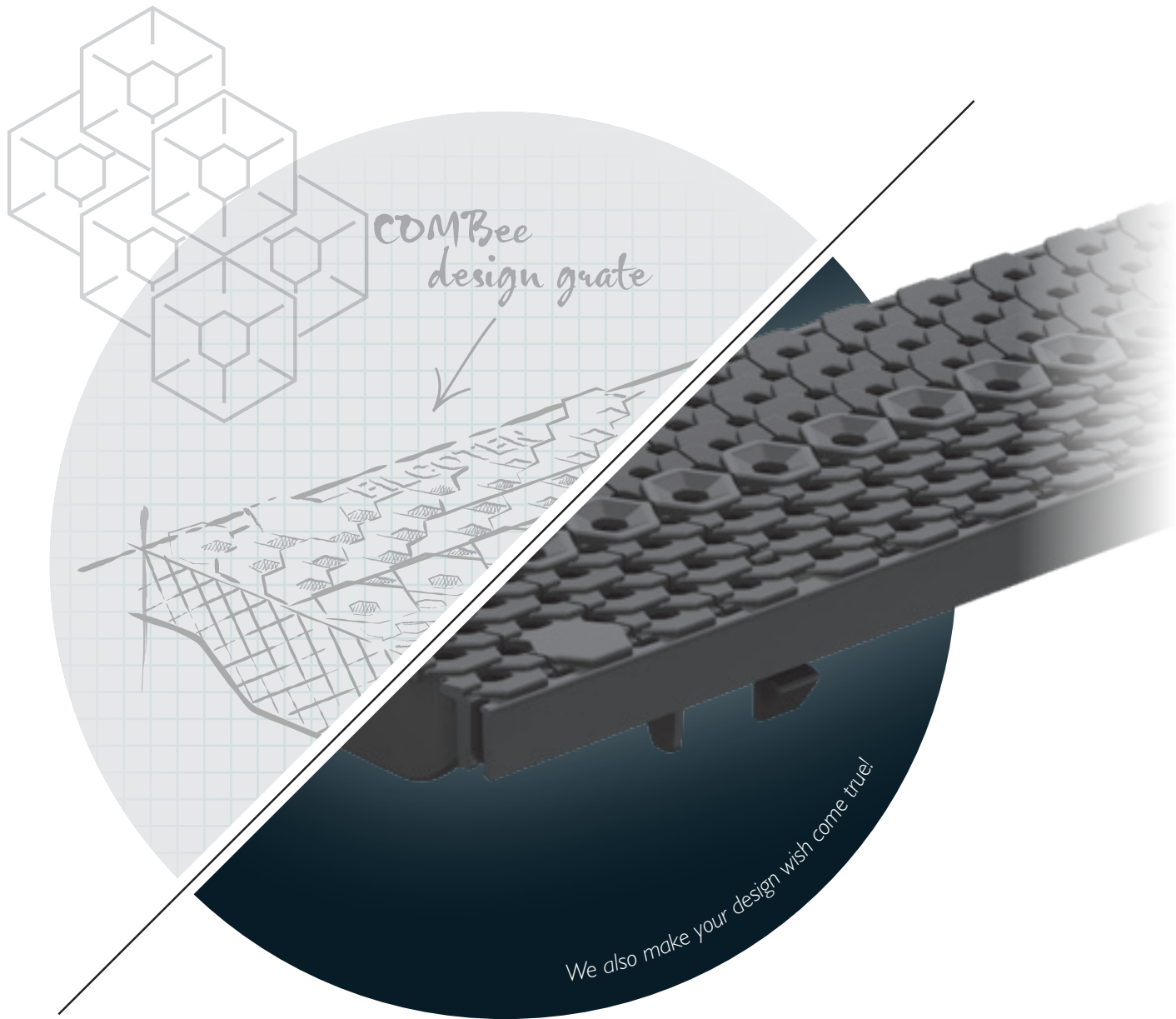

GRASPOINTNER
Sustainable innovation.



We also make your design wish come true!

The Art of Drainage

BG-BLACKLABEL
design line



[linkedin.com/company/
bg-graspointner](https://www.linkedin.com/company/bg-graspointner)



blog.bg-graspointner.com

Always up to date – with the
BG-blog and LinkedIn.

Just visit the BG- **Blog** and
link up with us on **LinkedIn**

BG

Functionality is good...
**Functionality
and superior
design is better.**



Above all, a good product has to function well. For products located in visible areas, in public spaces, as part of an architectural concept functionality means more. In such cases functionality additionally involves outstanding design.

An array of designs for every style and taste.

BG-BLACKLABEL is our comprehensive range of high-quality design grates for drainage systems. Products for every style and taste. So your works are not just completed on time, but also aesthetically pleasing.

Welcome to the world of BG-BLACKLABEL...

Yours

A handwritten signature in black ink, appearing to read 'Karl-Heinz Gramlich', with a stylized flourish at the end.

Karl-Heinz Gramlich

Rounded contours, exceptional design.

VILLE



» *The geometric form of the circle was my inspiration for the design of VILLE. It represents uniqueness and perfection.* «

Ulrich Groth | BG-Graspointner

The unusual contours of theVILLE design grate immediately catch the eye. Its circular openings have a quality that is at once geometric and organic, which lends an aesthetic completeness to a designer setting.

Made of high-quality EN GJS 500-7 ductile cast iron, the grate is extremely robust and durable, and suitable for all FILCOTEN® systems. Functionality and design in perfect combination.

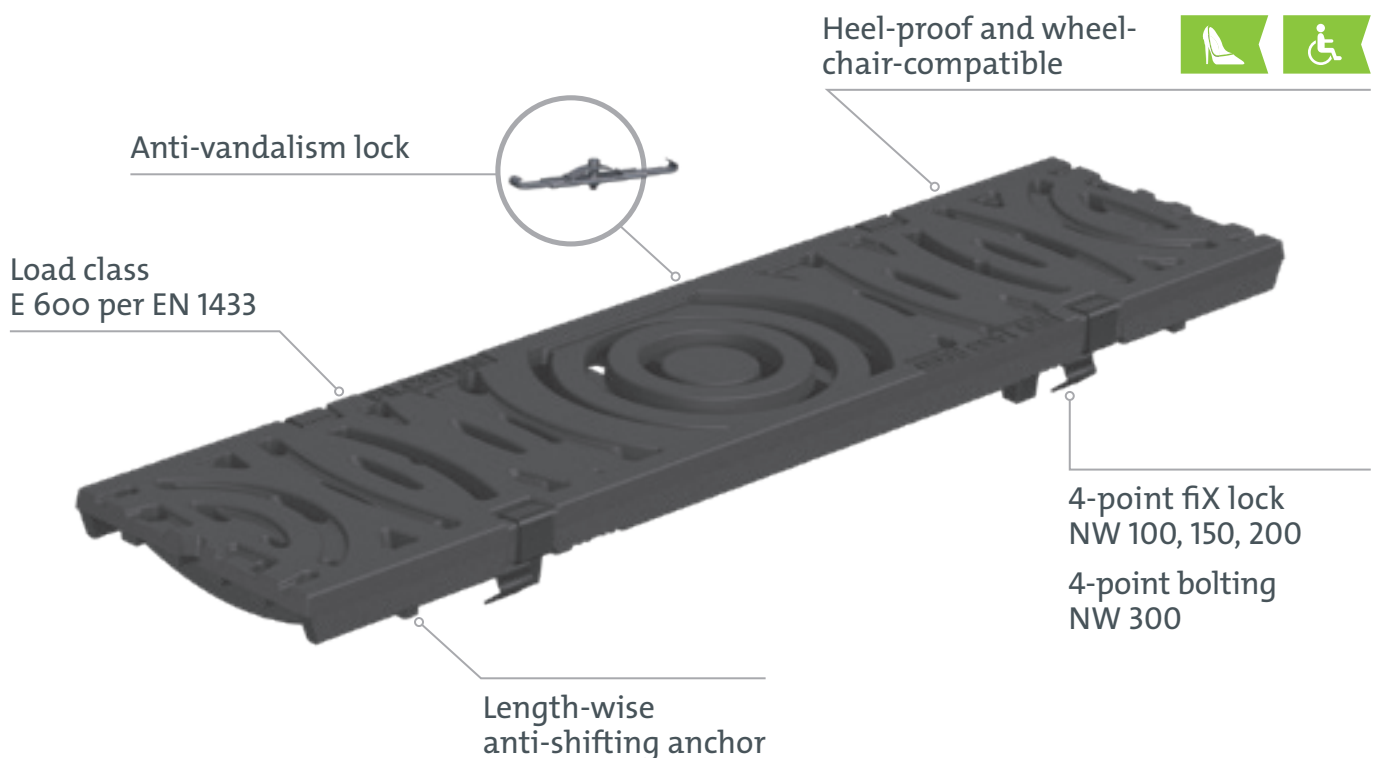



VILLE design ductile cast iron grate

Nominal width 100 / 150 / 200 / 300, cl. E600 per EN 1433

Item no.	Product	Locking system	L/W/H in mm	SW in mm
17010180	VILLE design ductile cast iron grate NW100	4-point fiX lock	500 / 122 / 20	7
17015180	VILLE design ductile cast iron grate NW150	4-point fiX lock	500 / 172 / 20	7
17020180	VILLE design ductile cast iron grate NW200	4-point fiX lock	500 / 222 / 20	7
17030180	VILLE design ductile cast iron grate NW300	4-point bolting	500 / 347 / 25	7

Delivery time on request

Flowing shapes, drainage perfection.

RIVER

»» *For me, the beauty of nature is quintessentially revealed in the harmonious flowing movements of a river – a thought has taken form in reality in this grate.*

««



Manuel Knoblochner | BG-Graspointner

The RIVER product brings a naturally flowing design element to your project. The contours of this design grate lend both playfulness and symmetry to sculpted spaces. Being both highly effective and economical makes it even easier to go with the flow of River.

For FILCOTEN®
drainage systems

ductile cast iron
EN GJS 500-7

Anti-vandalism lock



4-point fix lock
NW 100

Load class
D400 per EN 1433

Length-wise
anti-shifting anchor



GRASPOINTNER
Sustainable innovation.



RIVER design ductile cast iron grate

Nominal width 100, cl. D400 per EN 1433

Item no.	Product	Locking system	L/W/H in mm	SW in mm
	RIVER design ductile cast iron grate NW100	4-point fix lock	500 / 122 / 20	8

Delivery time on request

Gets more and more beautiful with age.

CORTEN STEEL

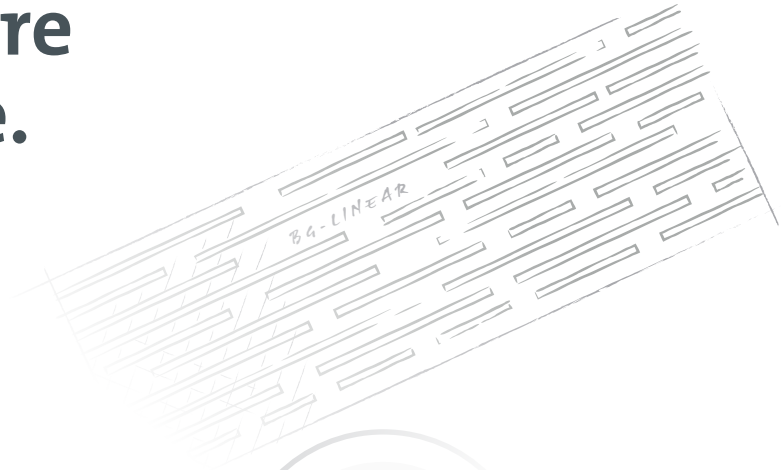

» *Materials can be dynamic and flexible – corten steel with its natural patina is a prime example.* «



Marcus Renn | BG-Graspointner

What materials actually look better over the course of time? CORTEN STEEL definitely does, which is a special kind of steel that develops an attractive orange-red protective layer (“patina”) when exposed to weather, giving it a very striking look. Positive side effect: The patina protects the steel from rust perforation.

Laser-precision cutting of your individual design.

And there are basically no limits on your creativity with this distinctive material in terms of shape and form. Tell us the individual design you envision, and we will laser-cut your grate with precision. Such grates are as unique as their designer.

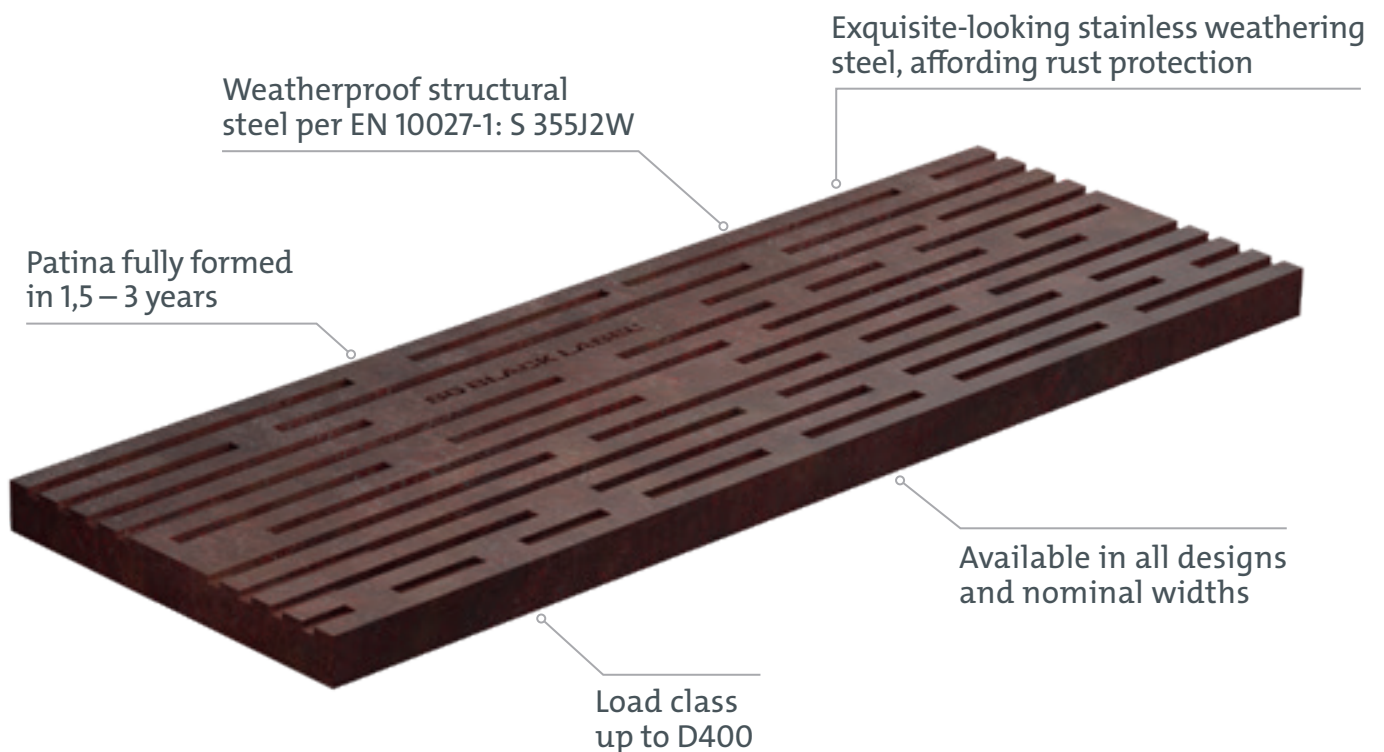

CORTEN STEEL RALLEY



CORTEN STEEL DIAMOND

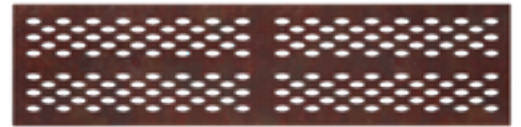

CORTEN STEEL LINEAR

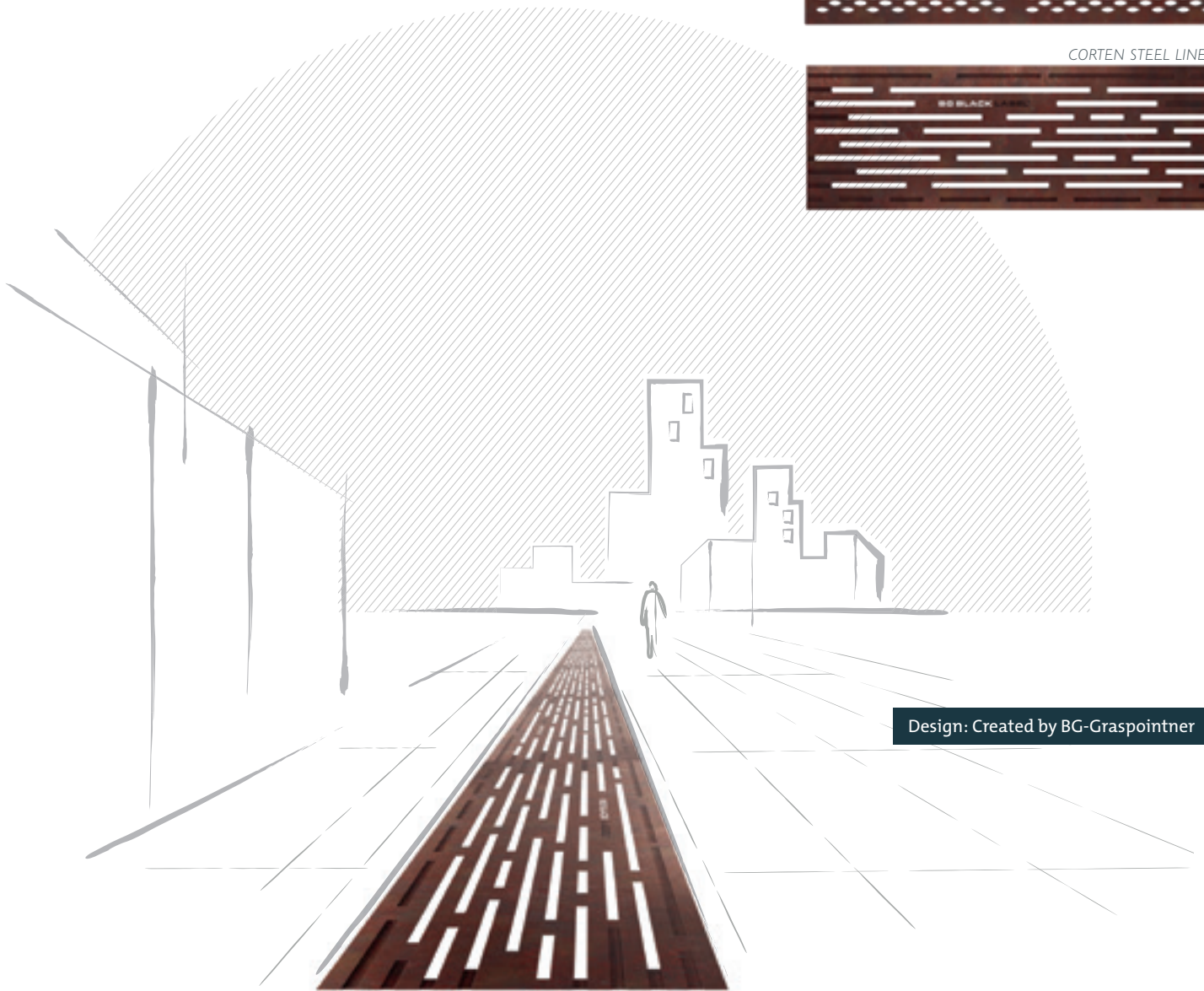

Design: Created by BG-Graspointner

The straight path to tasteful design.

KIARO

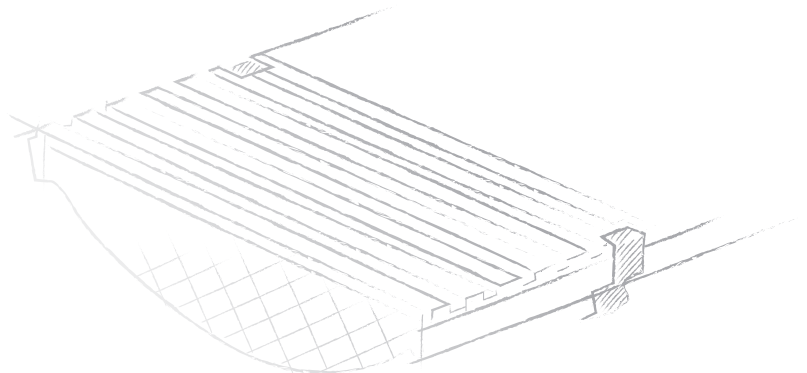

Clarity and straight lines define the look of this design grate for our FILCOTEN® drainage systems. With a smooth surface and high-quality, solid look, this model fits in well in an elegantly unadorned setting.

And looks do not deceive here, for KIARO is made of high-grade EN GJS 500-7 ductile cast iron. Superior design is united with functionality in this grate, which has several practical features.

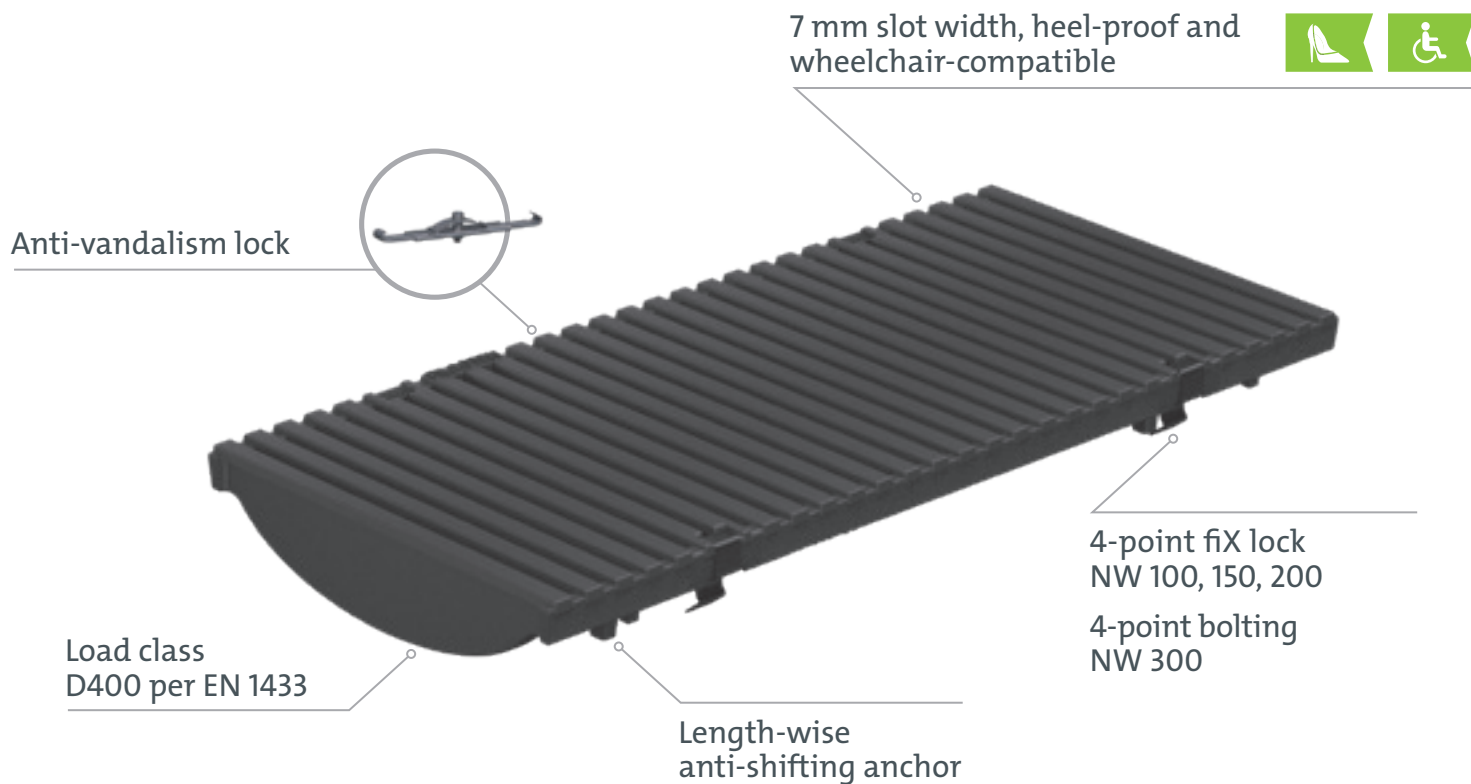

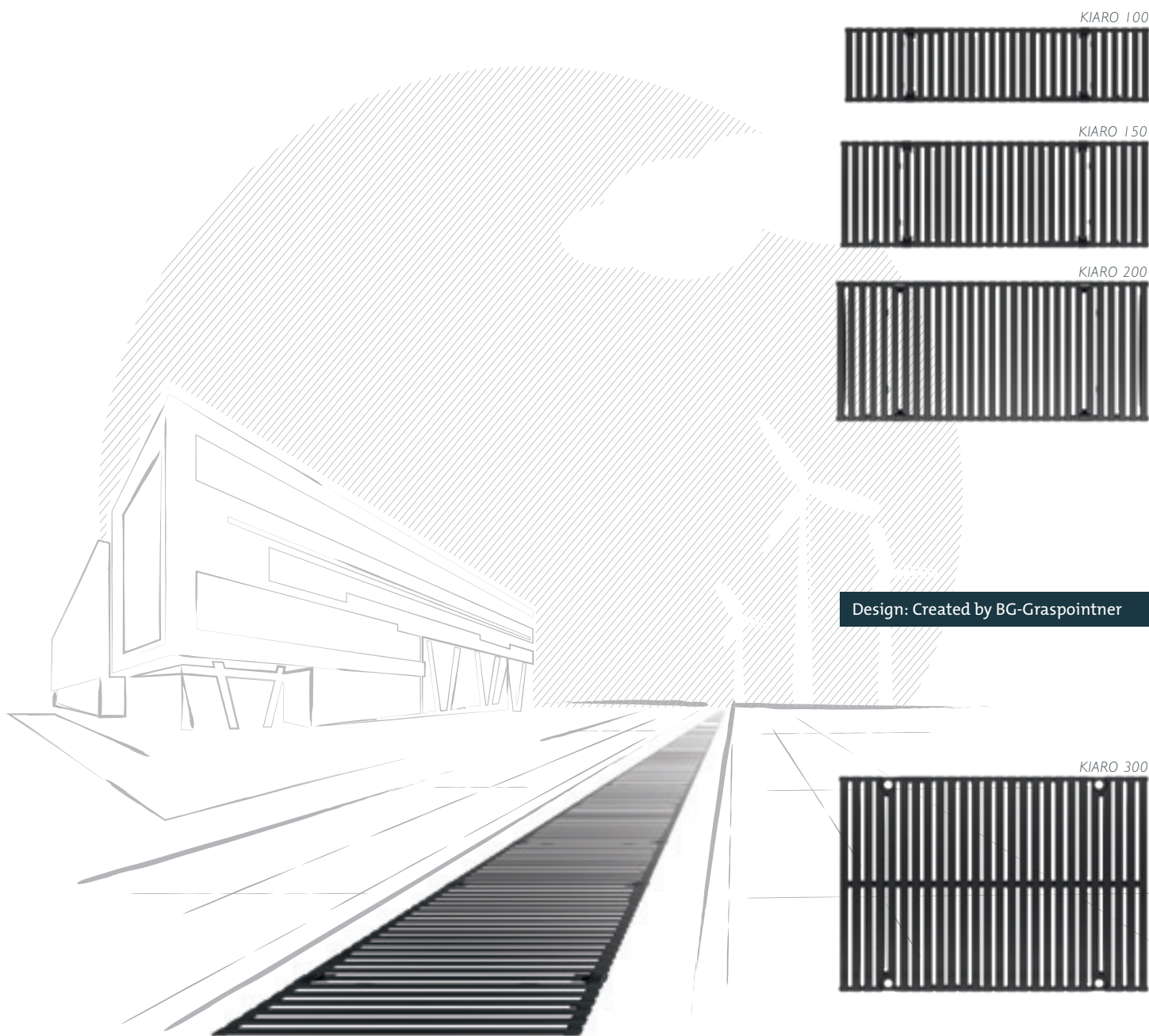

KIARO design ductile cast iron grate

Nominal width 100 / 150 / 200 / 300, cl. D400 per EN 1433

Item no.	Product	Locking system	L/W/H in mm	SW in mm
17010183	KIARO design ductile cast iron grate NW100	4-point fiX lock	500 / 122 / 20	7
17015183	KIARO design ductile cast iron grate NW150	4-point fiX lock	500 / 172 / 20	7
17020183	KIARO design ductile cast iron grate NW200	4-point fiX lock	500 / 222 / 20	7
17030183	KIARO design ductile cast iron grate NW300	4-point bolting	500 / 347 / 25	7

Delivery time on request

The path to stylishness.

VIA

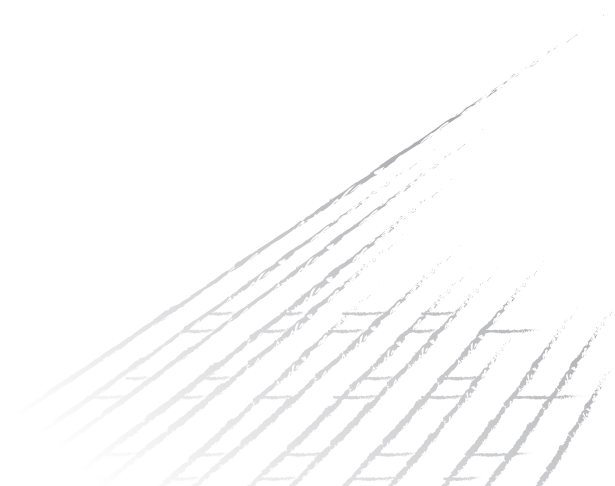

Like its close relative, the KIARO model, the design grate VIA also possesses qualities of clarity and straight lines – but rotated by 90 degrees. The VIA grate features longitudinal bars suitable for all FILCOTEN® drainage systems. Running length-wise rather than

cross-wise, the bars trace the path, blending even more subtly into the environment. With a smooth surface and similarly made of EN GJS 500-7 ductile cast iron, this attractive and extremely robust model has a massive and high-quality look.

7 mm slot width, heel-proof and
wheelchair-compatible



Anti-vandalism lock



Load class
D400 per EN 1433

Length-wise
anti-shifting anchor

4-point fix lock
NW 100, 150, 200
4-point bolting
NW 300



GRASPOINTNER
Sustainable innovation.

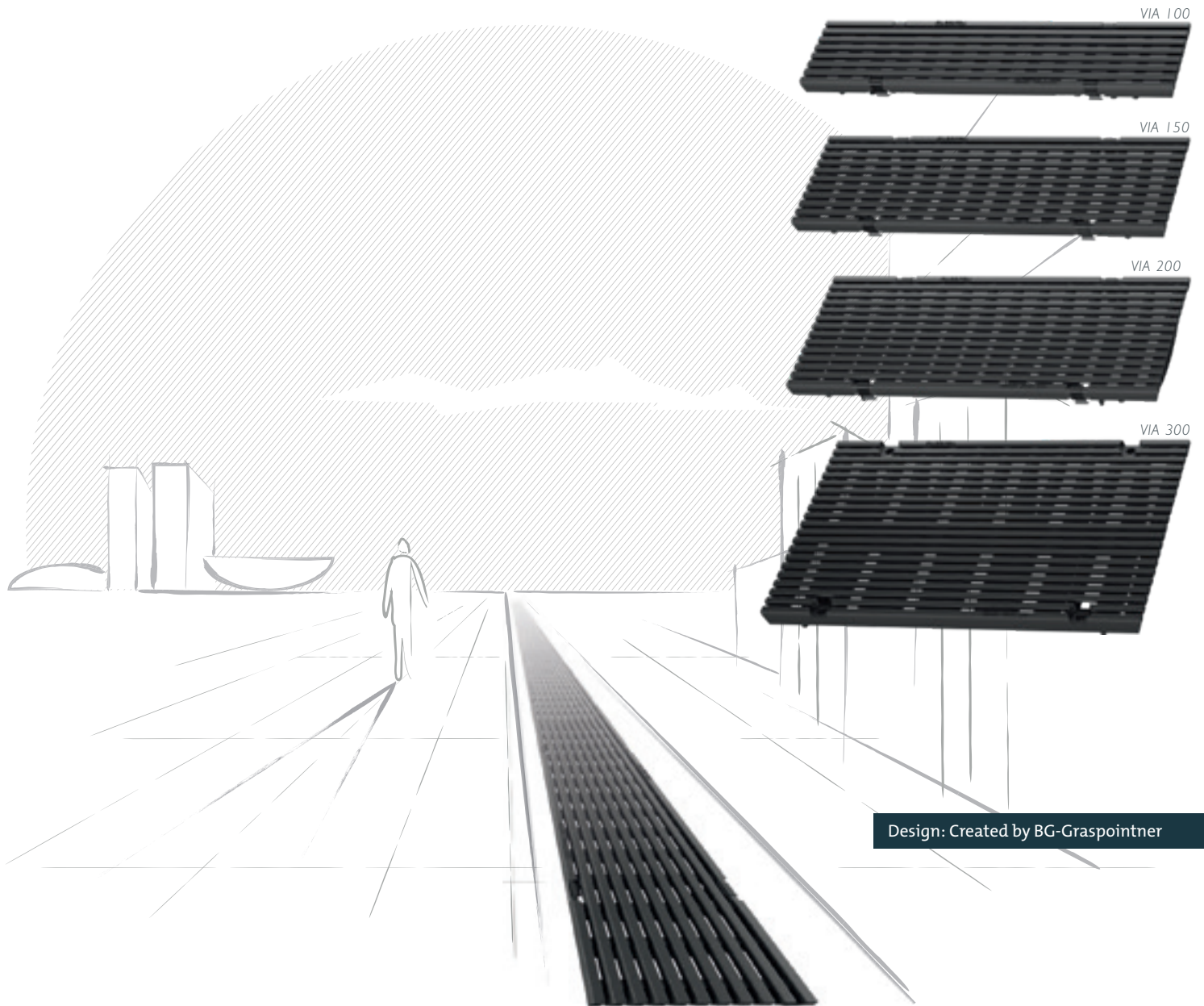

VIA design ductile cast iron grate

Nominal width 100 / 150 / 200 / 300, cl. D400 per EN 1433

Item no.	Product	Locking system	L/W/H in mm	SW in mm
17010184	VIA design ductile cast iron grate NW100	4-point fiX lock	500 / 122 / 20	7
17015184	VIA design ductile cast iron grate NW150	4-point fiX lock	500 / 172 / 20	7
17020184	VIA design ductile cast iron grate NW200	4-point fiX lock	500 / 222 / 20	7
17030184	VIA design ductile cast iron grate NW300	4-point bolting	500 / 347 / 25	7

Delivery time on request

Inspired by the glory of nature.

COMBEE

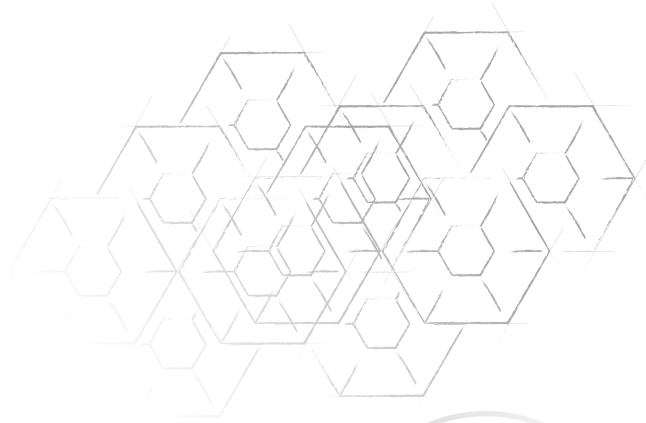

»» *Sometimes the small things are the most important ...
In design, greatness lies in the detail. This has to do with
my inspiration to give this grate a honeycomb pattern.* ««



Steffen Bernauer | BG-Graspointner

This eye-catching honeycomb design will raise the style level of any setting. As part of the BG-BLACKLABEL line – synonymous with technological excellence – the COMBEE is UV-resistant and extremely durable.

For FILCOTEN® channel systems made of PA6 polyamide. This semi-crystalline thermoplastic is very stable, has good damping and wear characteristics and is highly resistant to many oils, greases and fuels.

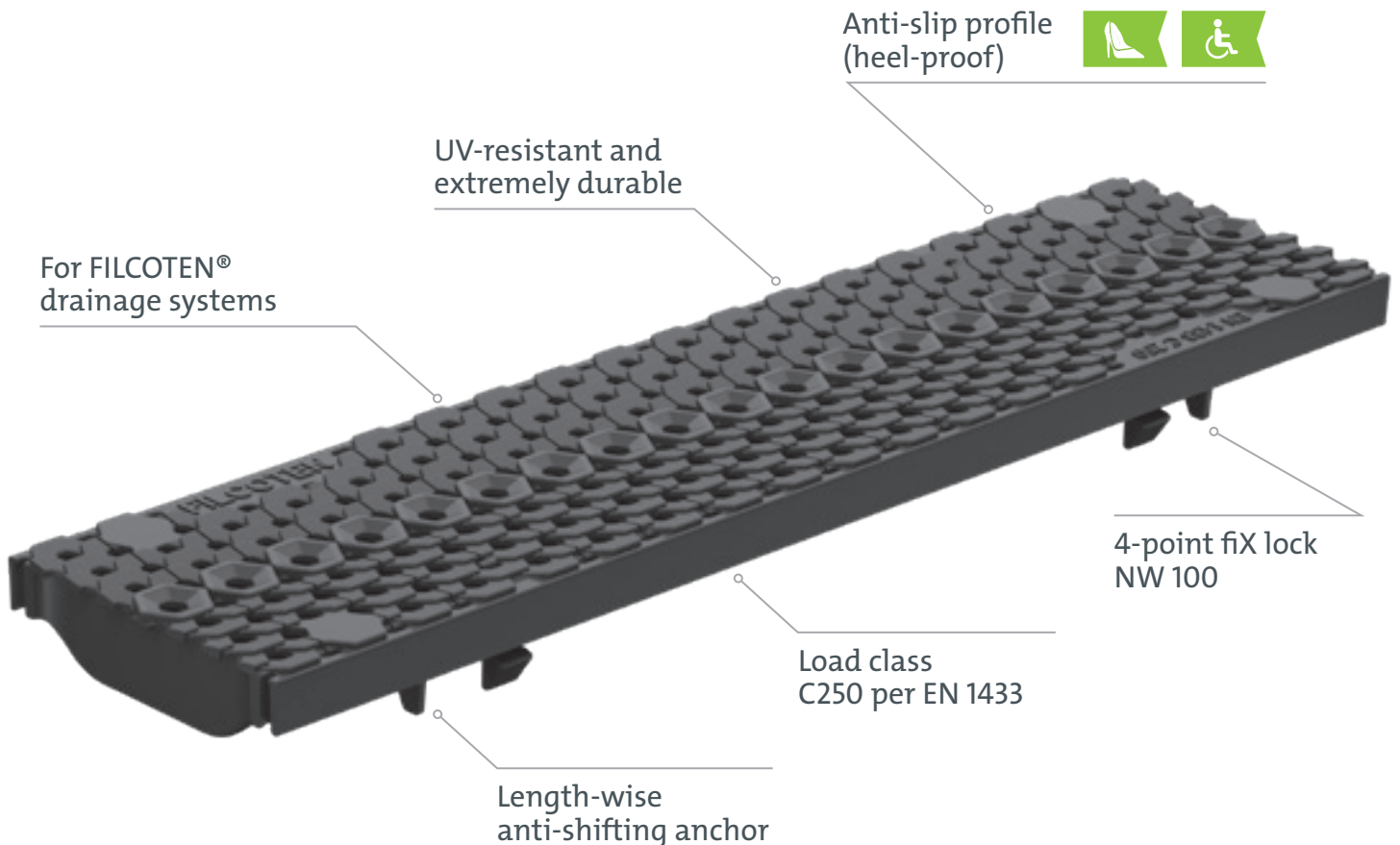

Anti-slip profile
(heel-proof)



UV-resistant and
extremely durable

For FILCOTEN®
drainage systems

Load class
C250 per EN 1433

4-point fix lock
NW 100

Length-wise
anti-shifting anchor



Design: Created by BG-Graspointner



COMBEE design grate

Nominal width 100, cl. B125 and cl. C250 per EN 1433

Item no.	Product	Locking system	L/W/H in mm	SW in mm
17010401	COMBEE design grate NW100, cl. B	4-point fiX lock	500 / 122 / 20	ø 7
17010402	COMBEE design grate NW100, cl. C	4-point fiX lock	500 / 122 / 20	ø 7

Delivery time on request

Design as an expression of your personality.

BLACKLABEL INDIVIDUAL

With BG-BLACKLABEL INDIVIDUAL your personal preferences and ideas are unbounded. Create your own design grate specifically for your project and leave the manufacturing to us. In close consultation with you of course, to ensure that your custom designer concept becomes reality.

Making your individual design grate.

- **Design phase**

Using sketches and drawings, you design the grate.



- **Planning and advice**

Contact us to arrange a consultation.



- **Implementation**

A technician makes a 3D design model based on your sketches.



- **Feedback**

You review the 3D model of your grate and provide feedback



- **Production**

After any adjustments are made based on your feedback, the grate goes into production in the desired quantity

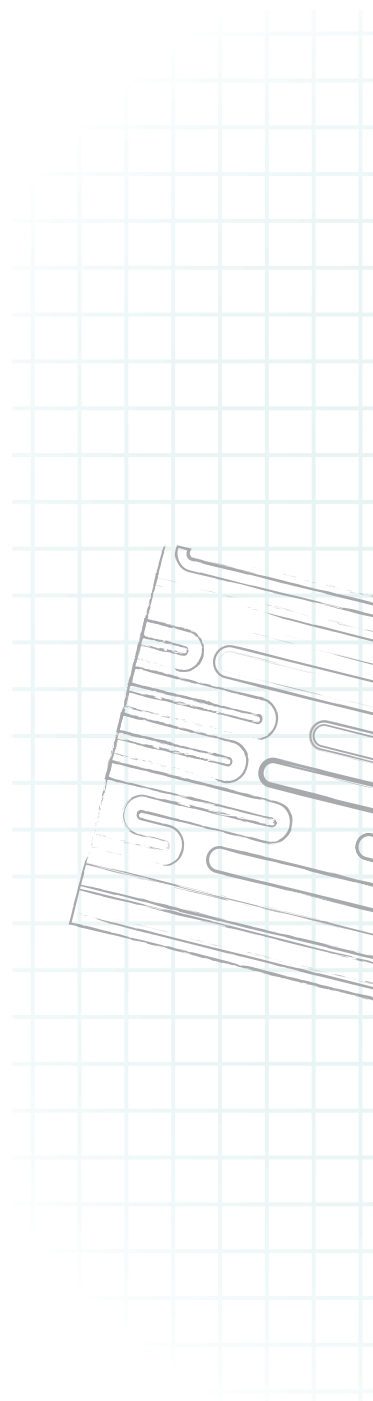

Your design sketch?

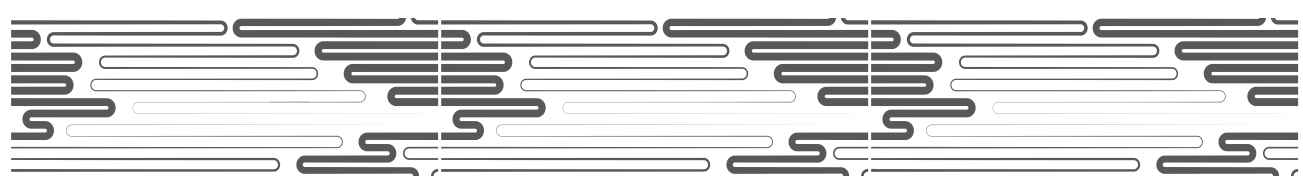
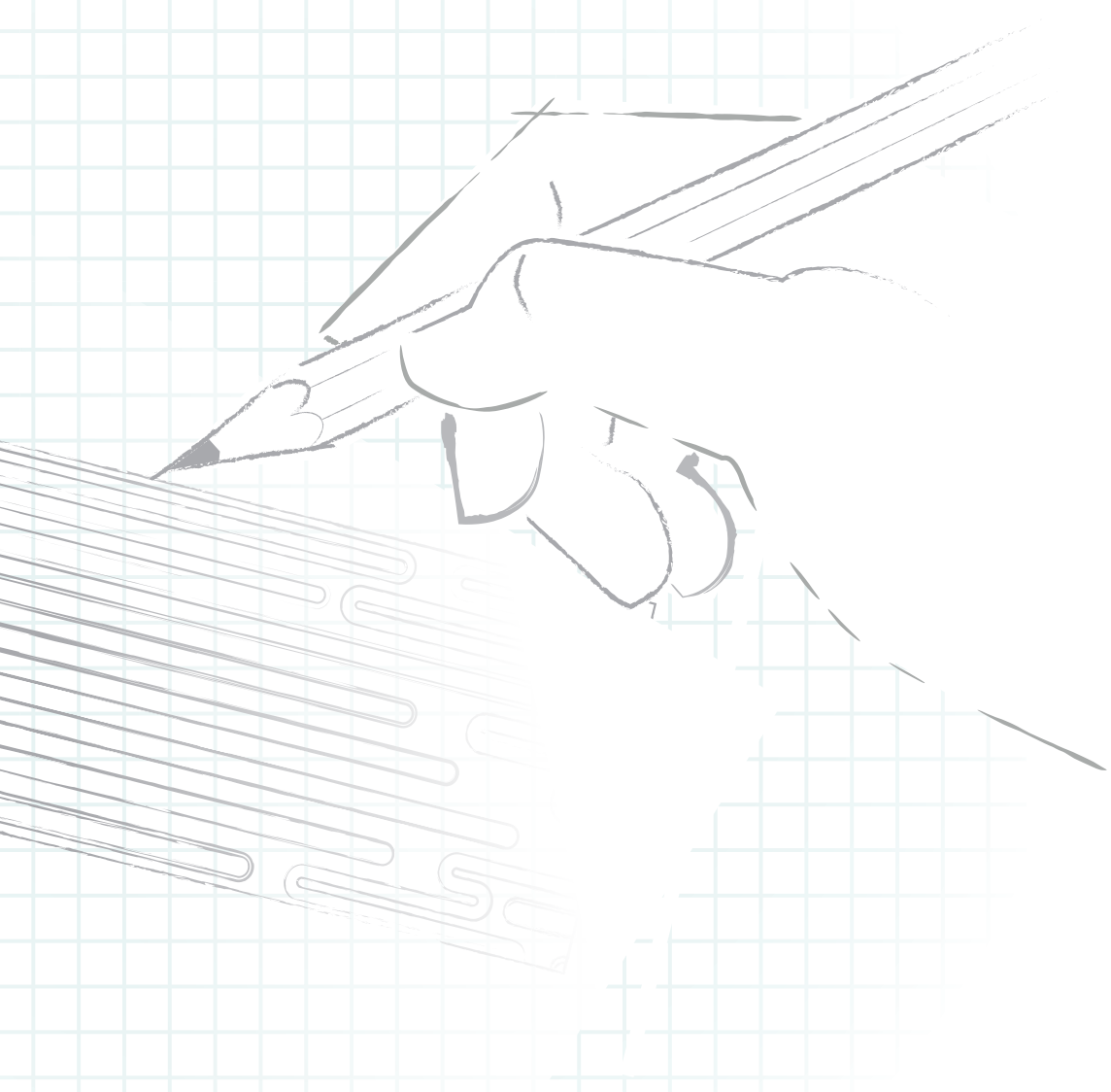

Elegance all down the line.

PIAZZA

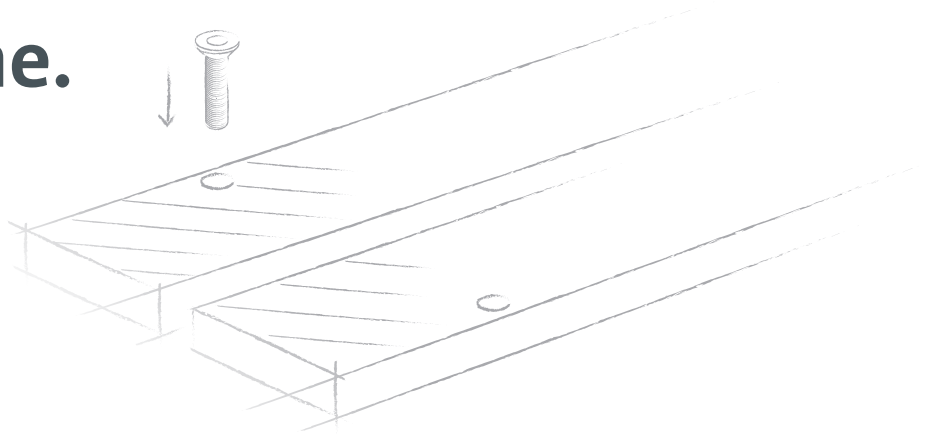

Restraint is often characteristic of good design – as seen with this attractive massive slotted grate. Its robust presence fits handsomely and elegantly into the environment, and is of course extremely efficient.

This massive, nearly closed slotted grate makes a bold impression as a design element, highlighting its top-quality production material.

Made of EN GJS 500-7 ductile cast iron, it is durable, stable, extremely efficient and suitable for all FILCOTEN® drainage systems.

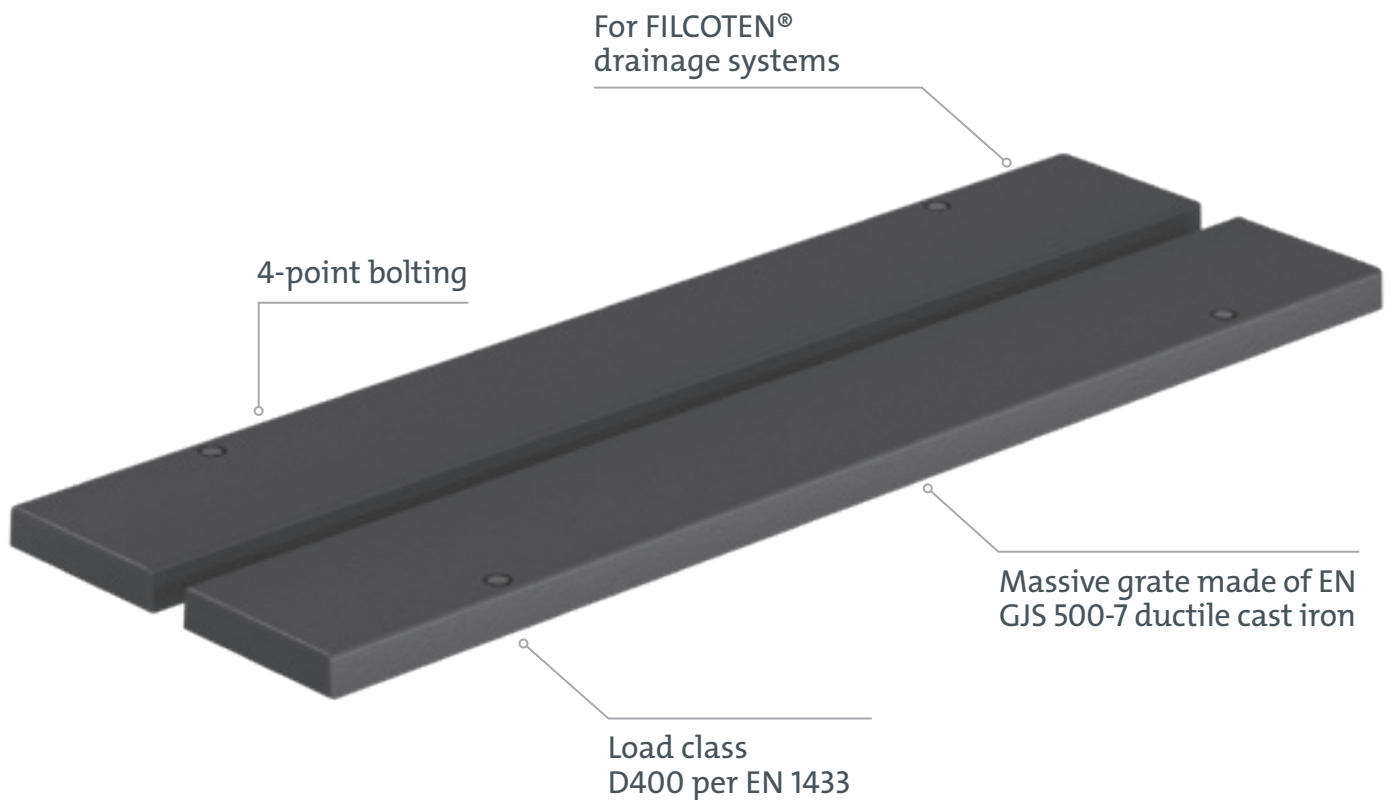



PIAZZA design ductile cast iron grate

Nominal width 100, cl. D400 per EN 1433

Item no.	Product	Locking system	L/W/H in mm	SW in mm
	PIAZZA design ductile cast iron grate NW100	4-point bolting	500 / 122 / 20	15

Delivery time on request

Because good design is unobtrusive.

SLOT TOP 2S HEELPROOF

High-quality meets subtle design. The slot top solutions made of stainless or galvanized steel have a lasting impression. Performance matches looks in this elegant, robust grating.

The high-quality slot top offers technical refinement, with a heel-proof dual-slot design and delivers excellent drainage performance.

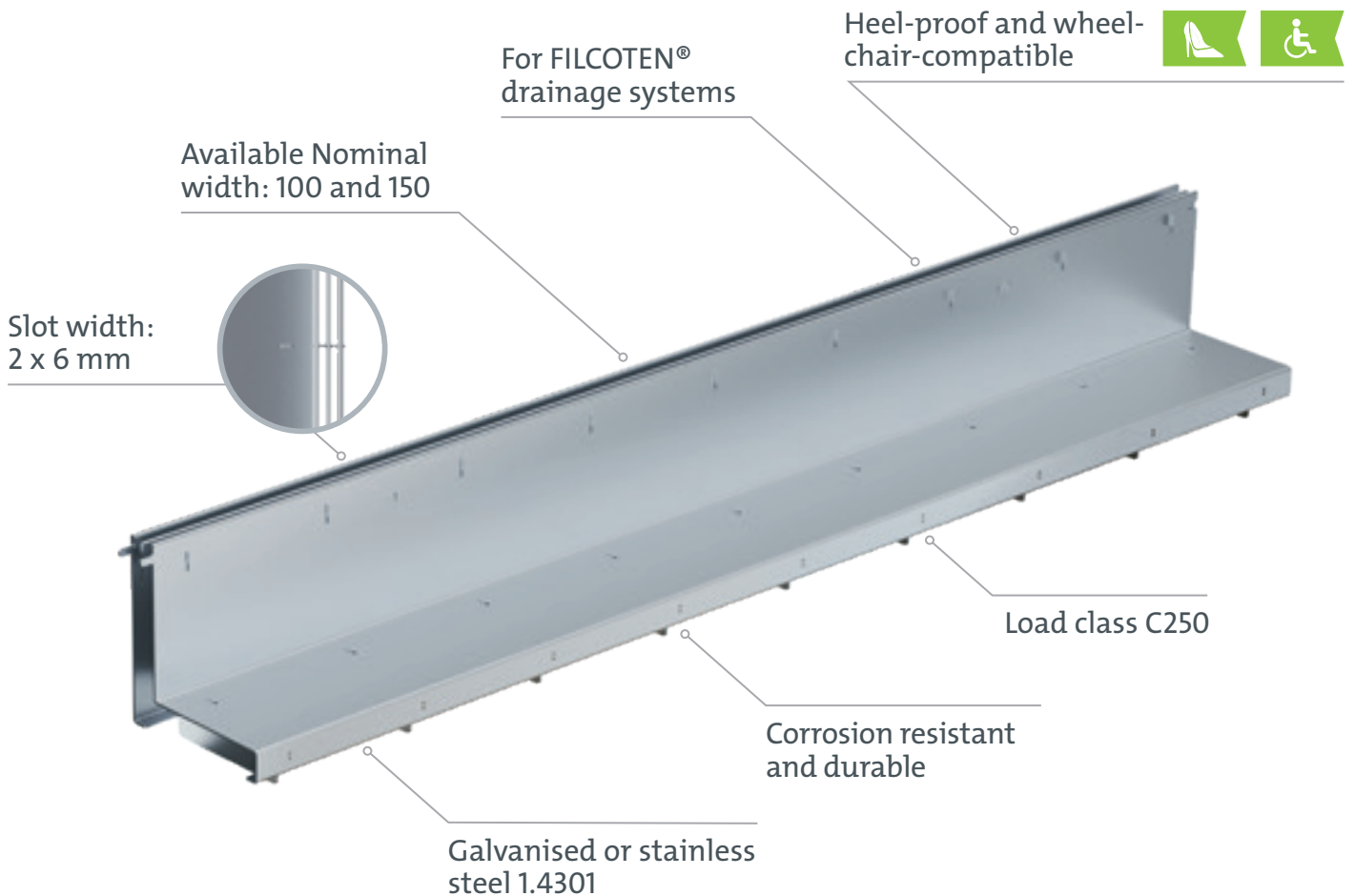
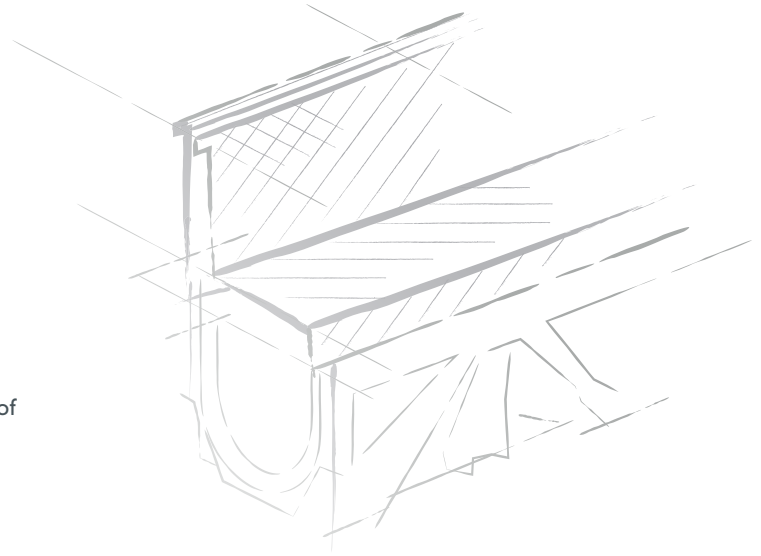

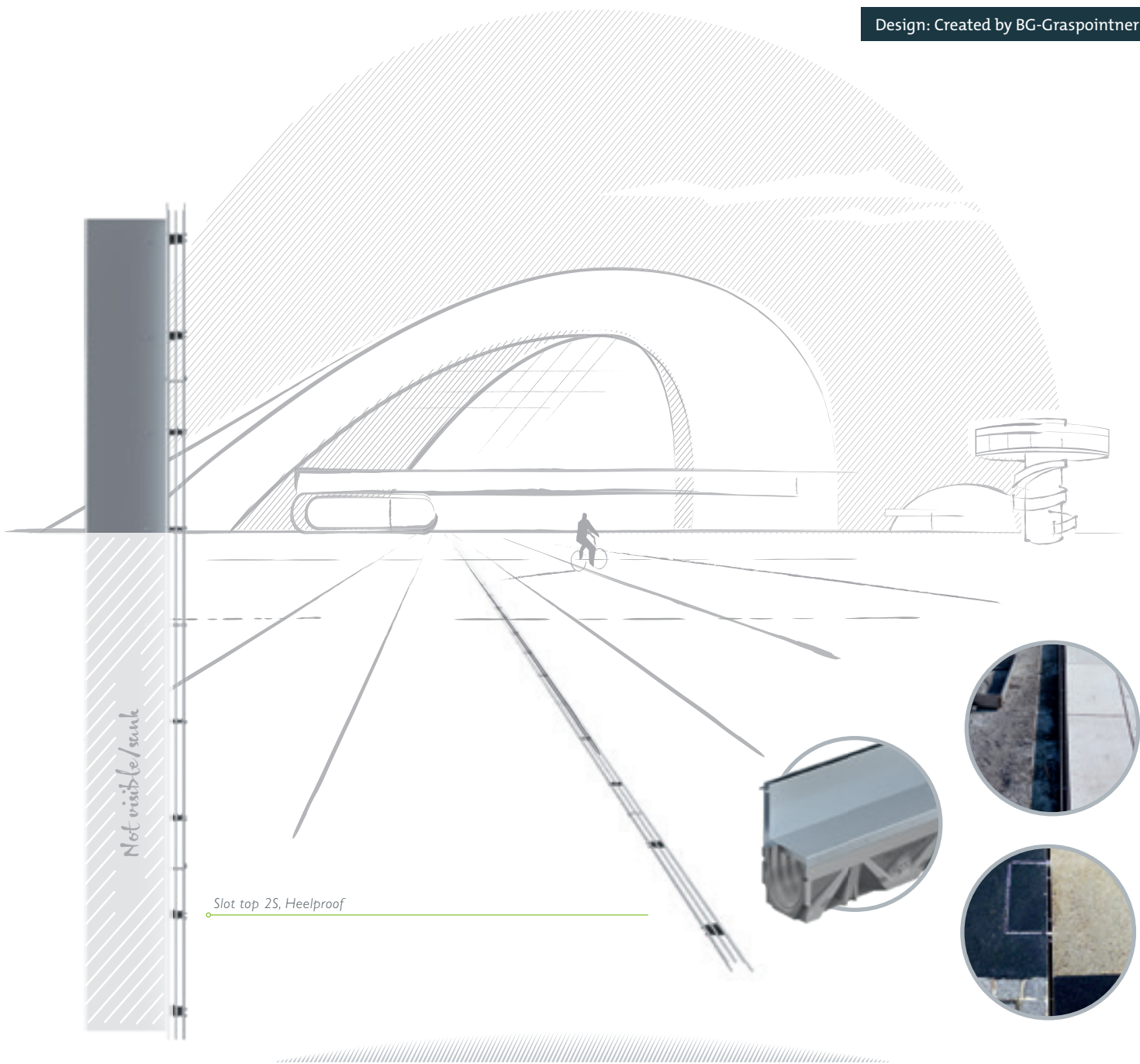

SLOT TOP 2S, HEELPROOF

Nominal width 100 / 150, cl. C250 per EN 1433

Item no.	Product	Material	L/W/H in mm	SW in mm
17111204	Slot top 2S, Heelproof NW100	galvanised	1000 / 123 / 133, SH110	2 x 6
17111205	Slot top 2S, Heelproof NW100	galvanised	500 / 123 / 133, SH110	2 x 6
17111304	Slot top 2S, Heelproof NW100	stainless steel 1.4301	1000 / 123 / 133, SH110	2 x 6
17111305	Slot top 2S, Heelproof NW100	stainless steel 1.4301	500 / 123 / 133, SH110	2 x 6
17116204	Slot top 2S, Heelproof NW150	galvanised	1000 / 180 / 133, SH110	2 x 6
17116205	Slot top 2S, Heelproof NW150	galvanised	500 / 180 / 133, SH110	2 x 6
17116304	Slot top 2S, Heelproof NW150 ^{*)}	stainless steel 1.4301	1000 / 180 / 133, SH110	2 x 6
17116305	Slot top 2S, Heelproof NW150 ^{*)}	stainless steel 1.4301	500 / 180 / 133, SH110	2 x 6

^{*)} Delivery time on request

Detailed planning for an outstanding system.

FILCOTEN® HPC is a high-performance concrete that combines outstanding technical properties with eco-sustainability. The optimised, high-density structure of HPC allows manufacturing of lightweight drainage channels that have the same stability and load capacity as conventional concrete systems. Less raw materials are required, the products are 100% recyclable¹⁾ and they are certified pollutant-free²⁾, making FILCOTEN® uniquely environmentally friendly.



FILCOTEN® pro / pro mini

- Galvanised edge protection, stainless steel, ductile cast iron
- Length 1000/ 500 mm
- FILCOTEN® pro:
 - NW 100/150/200/300/400 without slope
 - NW 100/150/200/300 with slope no. 1-10
- FILCOTEN® pro mini
 - NW 100/150/200/300
 - Height 60/80/100/120 depending on NW



Binds easily to the concrete bed

- lateral anchoring pockets for maximum anchorage in the concrete bed
- permanent fit in the foundation thanks to the identical linear expansion coefficient
- perfect connection between HPC and concrete

Sump unit

- Easy maintenance and cleaning of the drainage system
- Suspended silt bucket for sump unit
- Sealed pipe connection
- Length 500 mm

¹⁾ Quality class UA – certified by the Salzburg Construction Experimentation & Research Institute
²⁾ fulfils the strict criteria outlined by the Rosenheim Institute for Construction Biology (IBR)
³⁾ No synthetic resins used





Verified LCA
(Life Cycle Assessment)

- Reduced greenhouse gas emissions
- Manufactured with 100% green electricity
- Resource-saving manufacturing process

FILCOTEN[®] tec

- NW 100 with slope no. 1-10
- NW 150 BH 190
- NW 200 BH 195
- Galvanised or stainless steel edge protection
- Length 1000/500 mm

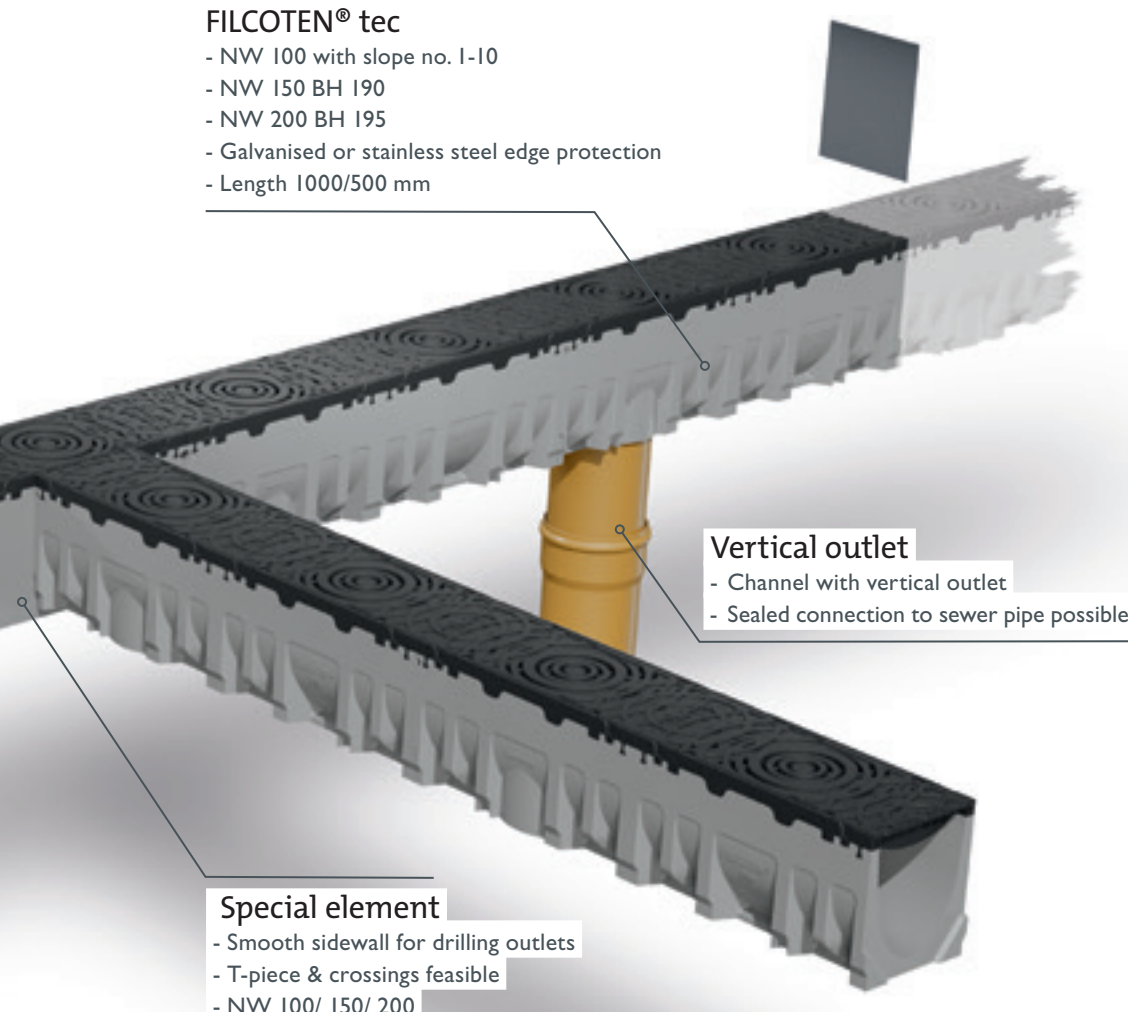

Vertical outlet

- Channel with vertical outlet
- Sealed connection to sewer pipe possible

Special element

- Smooth sidewall for drilling outlets
- T-piece & crossings feasible
- NW 100/ 150/ 200
- Length 500 mm BH No. 5-0

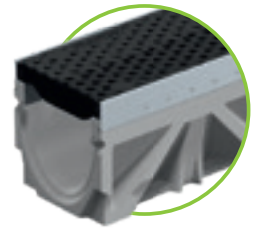

FILCOTEN[®] tec
Class C250



FILCOTEN[®] pro
Class E600



FILCOTEN[®] pro mini
Class E600



FILCOTEN[®] pro
Class F900

Sustainability in action:

FILCOTEN[®] HPC (High Performance Concrete)

- Cement-bonded mineral material
- Extremely durable, permanently stable, UV-resistant
- Maximum resistance to frost and de-icing salt
- Certified 100% recyclable¹⁾
- Environmental & energy management certified under ISO 14001/50001 at the plant in Oberwang, Austria
- IBR²⁾-tested, biologically safe

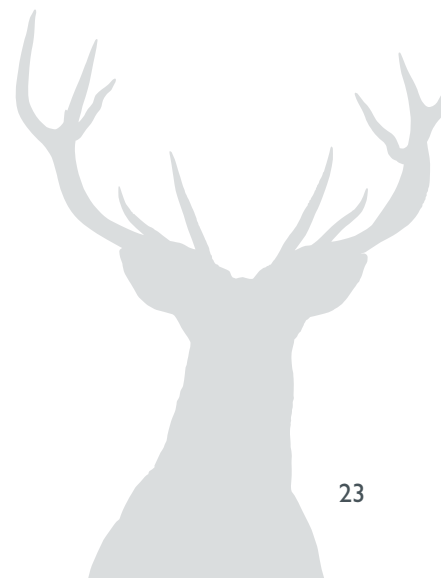

Because a thing of beauty should last. **MATERIALS USED**

Premium materials are exclusively used in BG-BLACKLABEL design grates. The products are tremendously robust, durable and high-quality. These features manifest in the look and feel and come along with their outstanding design.

DUCTILE CAST IRON

We use high-quality, graphite-rich ductile iron, also known as spheroidal or nodular cast iron to manufacture our grates and covers. The specific properties of EN GJS 500-7 make it the ideal material for ductile cast iron grates.

CORTEN STEEL

Corten steel (aka Cor-Ten or weathering steel) is a special kind of steel which develops a special protective coating called a "patina" after being exposed to weather over a certain period of time.

Positive side effect: The patina protects the steel from rust perforation. The patina is a naturally forming orange-red layer that is visually appealing and protects the steel so it will not rust through, making it a superb material for crafting interesting, design elements like our channel cover. Corten steel covers per EN 10027-1: S 355J2W are precision-cut and refined by laser.

POLYAMIDE PLASTIC

Our COMBee grate is made of the plastic polyamide, a semi-crystalline thermoplastic that has balanced mechanical properties. Polyamide is durable, has good damping and wear properties and is resistant to many oils, greases and fuels.

GALVANISED STEEL

We use Z275 galvanised sheet steel for many of our steel products, like our Slot tops. Both sides are hot-dip galvanised to extend the useful life of the finished product by protecting the steel against corrosion. The properties of the zinc coating afford corrosion protection even for areas where steel surfaces are exposed, such as cut edges.

STAINLESS STEEL

Nearly all of our steel products are available in 1.4301 stainless steel as well, often referred to as AISI 304. This is an austenitic, acid-resistant chrome-nickel steel that has very good polishability and especially good formability for deep drawing, bending and roll forming. Because of its good corrosion and acid-resistance properties, stainless steel is used for a wide variety of applications, including the food industry and swimming pools.



Areas of use.

CLASSIFICATION AS PER EN 1433

Channels or covers and gratings are divided in different classes according to the areas of use.

ex. Class: **C 250**

code letter Load class in kN
(minimum value of
the maximum load)

Load class	Areas of use
 A 15 Load class 15 kN	Traffic areas which are only used by pedestrians and cyclists and similar areas e.g. urban green and open spaces.
 B 125 Load class 125 kN	Sidewalks, pedestrian areas and comparable areas, car parks or car parking decks, garages, driveways.
 C 250 Load class 250 kN	Applies only to tops / drainage channels in the curbstone-area, which may extend 0.5 m into the carriageway and 0.2 m into the sidewalk measured from the curbside, and for untraveled road verges.
 D 400 Load class 400 kN	Carriageways of roads (including pedestrian zones), road verges, car parks and similar fortified thoroughfares.
 E 600 Load class 600 kN	Private thoroughfares which are used by vehicles with heavy wheel loads, e.g. routes for industrial construction traffic.
 F 900 Load class 900 kN	Areas which are used by especially heavy wheel loads, e.g. air traffic areas of commercial airports.

Knowledge is power – especially with such fine products...

ADDITIONAL BROCHURES AND CATALOGUES.

All brochures and catalogues are available for download on our website. A convenient way to find out about our entire product range.

 bg-graspointner.com/brochures

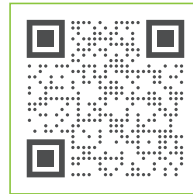

FILCOTEN® one

The first of its kind – and the most sustainable. The monolithic line drainage system made from FILCOTEN® HPC is for dynamic exposure in road traffic, extremely robust and safe.



Product catalogue

Whether FILCOTEN® HPC, steel or concrete, we have the right solution for you. Discover the variety of BG-products in our product catalogue.



FILCOTEN® green

We are setting a new Purity standard for surface water. The FILCOTEN® green has an innovative filter system that impresses with its outstanding cleaning performance.



FILCOTEN® Brochure

Sustainable in every respect, high-performance down to the last fiber – or simply FILCOTEN®. See for yourself our drainage systems made of FILCOTEN® HPC.



FILCOTEN® parkline

More potential than anyone else – in not more than just drainage. The monolithic drainage system especially for park garages.



Steel channels

Flexible for all requirements. Steel stands for long durability. BG-Graspointner stands for high-quality workmanship. The ideal combination for your drainage situation.





GRASPOINTNER
Sustainable innovation.



blog.bg-graspointner.com/int/print

BG-Graspointner GmbH
Gessenschwandt 39
4882 Oberwang
AUSTRIA

Tel.: +43 6233/89 00-0

Fax: +43 6233/89 00-303

E-Mail: office@bg-graspointner.com

Web: www.bg-graspointner.com

Find out more about our commitment to sustainable print products in our blog article.

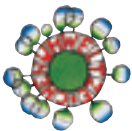

Printed according to criteria documents of the austrian Eco-Label „printed products“. gugler®print, Melk, UVZ-Nr. 609, www.gugler.at



This product is made of material from well-managed, FSC®-certified forests and other controlled sources.

greenprint*
carbon positive printed

* Our contribution to the reforestation project of BOKUWien in Ethiopia.

Your Partner for BG-Graspointner Drainage Systems